

MHP808-SK2 DOUBLE BOWL SINK



Description

- Model MHP808-SK2 is our stainless steel double bowl sink
- Conforms to HBN 00-10 Part C and HTM64 hospital standards
- Manufactured from grade 304 stainless steel, 1.2mm thick
- Tap holes drilled to customer specification
- Fully radiused, easy to clean corners

Delivery

- In stock, 2 to 3 working days

Dimensions

- **Length:** 1200mm
- **Front to back:** 600mm
- **Depth:** 200mm

Includes

- Stainless steel wall brackets
- 38mm waste fitting

Optional Extras

RES-BOTTLETRAP - plastic resealing bottle trap

MHP-FL - front support legs

TAPS FROM OUR EXTENSIVE RANGE

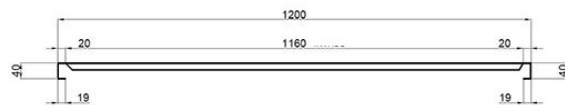
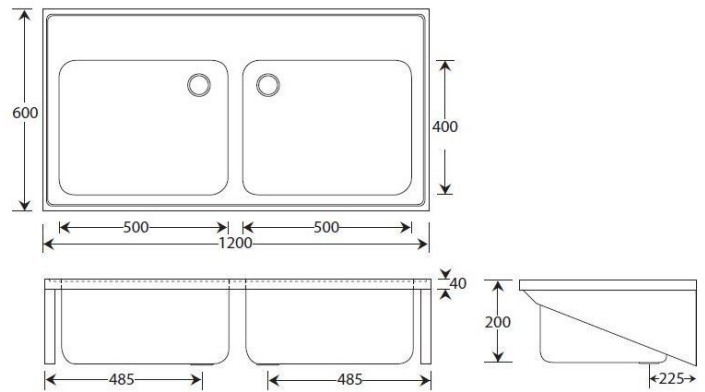

Shown without wall brackets

